



## Experience

With over 50 years experience to call on, HAKI has gained a leading reputation in its field. With its own R & D and manufacturing facilities, the company now operates throughout Europe and its equipment is in use worldwide. With all scaffolding products designed and manufactured to BS EN 12810 and a quality system to BS EN ISO 9001:2000 coupled with a comprehensive training and support infrastructure, you can rely on HAKI for support.



## Training

The Company's Centre of Excellence is equipped with the full range of HAKI products where a comprehensive choice of training courses is offered. With the benefit of this training, all users of HAKI products can be assured that the equipment is being employed safely and effectively.



## Support

From computerised estimating facilities to on site assessment and project back up, HAKI is with its customers every step of the way. Working with HAKI means far more than just proven equipment, it means working with people who understand the scaffolding industry. Whatever the project, the company is committed to ensuring every user enjoys the full benefits associated with the use of HAKI - maximising time savings, safely, profitably, and above all, SAFETY.

### Health and Safety at Work Act, 1974

HAKI equipment is designed to meet the requirements of the above Act, Section 6. It is also the customer's responsibility to comply with the requirements of this Act, particularly to use the equipment in accordance with current codes of practice and in ensuring that components are in good working condition prior to each use. We are able to provide assistance and advice on matters relating to safe and proper use of HAKI equipment.



SPECIALISTS IN SCAFFOLDING AND WEATHER PROTECTION SYSTEMS

HAKI Ltd. Magnus, Tame Valley Industrial Estate, Tamworth, Staffordshire B77 5BY

Phone: (01827) 282000 Fax: (01827) 285400

info@haki.co.uk www.haki.co.uk



## USER'S GUIDE for

# HAKITEC<sup>®</sup> 750

## SYSTEM SHELTER



## READ THIS MANUAL BEFORE COMMENCING ERECTION.

### INTRODUCTION

**All Shelters are subject to individual design, particularly those outside the scope of this guide.**

This book is a guide to erecting a HAKI Temporary Shelter by competent operatives in a safe, efficient procedure.

It is the contractor's responsibility to ensure Shelters are securely fixed in position either by adequate Kentledge or Anchors.

If in doubt please contact HAKI Technical Department at Tamworth, Staffordshire on 01827 282525 or email us at info@haki.co.uk.



## WARNING



**ALL INFORMATION CONTAINED IN THIS MANUAL APPLIES ONLY TO COMPONENTS MANUFACTURED AND SUPPLIED BY HAKI.**

**ANY COMPONENTS ORIGINATING FROM OTHER SOURCES WHICH ARE INCORPORATED INTO A STRUCTURE WILL INVALIDATE THIS INFORMATION.**

**IN SUCH CASE, HAKI HAS NO PRODUCT LIABILITY.**

**BY MIXING COMPONENTS OF OTHER MANUFACTURE THIS MAY INVALIDATE INSURANCE POLICY COVER.**

**FAILURE TO FOLLOW INSTRUCTIONS CONTAINED IN THIS GUIDE COULD RESULT IN UNSATISFACTORY PERFORMANCE AND DAMAGE TO COMPONENTS.**

## INSPECTION CHECKLIST

All structures should be inspected

- On completion
- Every seven days
- After adverse weather conditions
- After adaptations or movement

1. Is the ground condition adequate to take the load imposed?
2. Are all components in their correct position and all locking catches engaged e.g. Lacing Frames, Plan Braces and Spring Pins?
3. Have any items been removed?
4. Is the shelter adequately braced and anchored?
5. Check - Are all Spring Pins fully engaged?
  - Are the Saddle Clamps Bolts securely fixed to the Hakitrak and Beams?
  - Are the sheets fully tensioned correctly with ratchet straps?

## EQUIPMENT REQUIRED TO BE SUPPLIED BY CUSTOMER













- 1) Rope Line x 2 (length approx. 20m long)
- 2) 22mm Open Ended Spanner or ADJ Spanner
- 3) Recommended 3 competent persons to erect
- 4) Anchors/Kentledge
- 5) Crane Lifting (contact HAKI for details)
- 6) Shelters are normally supplied with sheeting to cover roof and sides only. If Gables are required to be sheeted, extra sheets and tube/fittings to attach to gables are required.
- 7) Cable Ties or similar.

## PREVENTING UPLIFT OR OVERTURNING

Anchor Forces or Kentledge at each Shelter Leg Position				
	6.9m Shelter	8.8m Shelter	11.2m Shelter	14.6m Shelter
South East	220 kgs	300 kgs	440 kgs	570 kgs
South West	280 kgs	400 kgs	560 kgs	730 kgs
Central	280 kgs	400 kgs	560 kgs	730 kgs
North West	360 kgs	510 kgs	700 kgs	910 kgs
North East	320 kgs	450 kgs	630 kgs	820 kgs
Scotland	400 kgs	620 kgs	810 kgs	1100 kgs

These values are for guidance only. A full assessment of site conditions should be made to determine appropriate preventative measures.

## SHELTER COMPONENTS

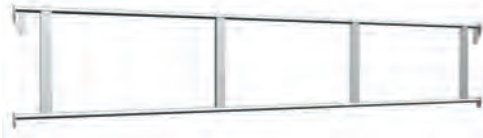
Name		
<b>Base Jack for Static Shelter</b> 2071000  4.7kg		<b>Adjustable Leg Nylon Wheel</b> 2012001  10.2kg
<b>Rolling Roof Wheel</b> UK2591316  12.2kg		
<b>2m Shelter Leg</b> UK7012109  12kg		<b>Access Shelter Bracket</b> UK7012112 7.4kg  
		<b>0.5m FSH Standard</b> 7017051 3.3kg <b>1.0m FSH Standard</b> 7017101 6kg <b>1.5m FSH Standard</b> 7017151 8.4kg <b>2.0m FSH Standard</b> 7017201 11.2kg
<b>1.25m Diagonal Brace</b> 7122120 7.8kg <b>1.655m Diagonal Brace</b> 7122160 9.8kg <b>2.5m Diagonal Brace</b> 7121250 13.6kg <b>3.05m Diagonal Brace</b> 7121300 15.6kg		
<b>6.25m Beam</b> 4032625  46kg		<b>3.25m Beam</b> 4032325  24kg
		<b>2.25m Beam</b> 4032225  16.8kg
		
<b>15° Ridge Beams</b> 4202260  18.7kg		<b>Connector Tubes</b> 7203001  19kg
		
<b>Spring Pin for fixing Aluminium Beams, Legs and Saddle Clamps</b> 2113100  0.07kg		<b>Pin &amp; Chain</b> 5141256  0.2kg
		

## SHELTER COMPONENTS

### Name

**3m Lacing Frame**  
7052301

14.9kg



**3.05 x 2.25m Plan Braces** 7503022

6kg

**3.05 x 2.00m Plan Braces** 7503020

4kg



**HAKI Trak 6.25**

7541625

12.9kg



7 Saddles required

**HAKI Trak 3.25**

7541325

6.7kg

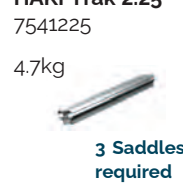


4 Saddles required

**HAKI Trak 2.25**

7541225

4.7kg



3 Saddles required

**Saddle Clamp**

7541000

0.65kg



**HAKI Trak 15° Ridge**

7541015

2.8kg

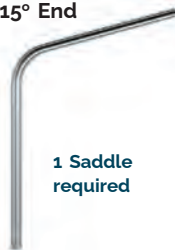


2 Saddles required

**HAKI Trak 15° End**

7541150

3.3kg



1 Saddle required

**Joiner**

7540001

0.03kg



**Seal**

7540002



**Ratchet Strap**

7540003

0.5kg



## SHEETING SPECIFICATION

### TECHNICAL SPECIFICATION 541

BASE FABRIC: POLYESTER

DECITEX: 1100

COATING: FLEXIBLE PVC BOTH SIDES

COATED

WEIGHT: 610 gms/m<sup>2</sup>

COLOUR: WHITE

METHOD 6: TENSILE STRENGTH

METHOD 7B: TEAR STRENGTH  
(Breaking Load)

METHOD 9B: COATING ADHESION

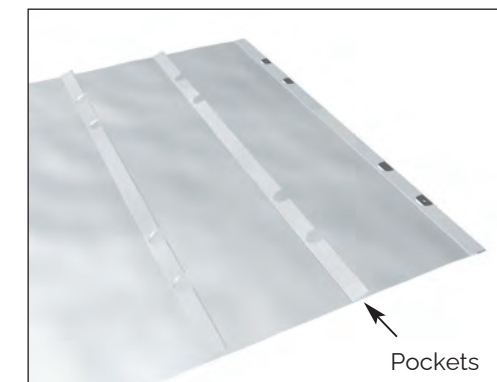
TEMPERATURE RESISTANCE: -20°C

FLAME RETARDANT TO BS5438 2A (NO FLAME OR AFTER GLOW)

NOTE: These are typical results intended for guidance only. We cannot accept liability for any injury, loss or damage resulting from reliance upon such information.

#### (Minimum Figures)

	N/50mm	lb/2"	kg/50mm
Warp	2500	568	250
Weft	2000	454	200
Warp	375	84	37
Weft	330	75	33
	65		6



TYPE A 2742030

WIDTH: 3.05m  
LENGTH: 16.88m

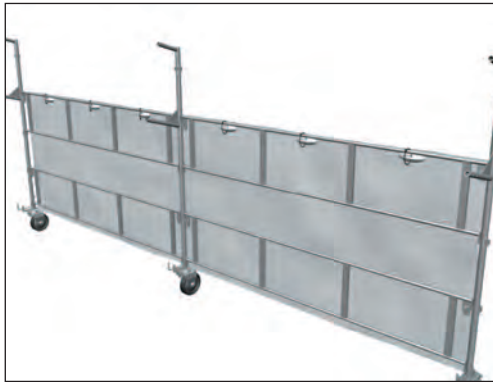
TYPE B 2742029

WIDTH: 3.05m  
LENGTH: 10.88m

WALL SHEET 2742026

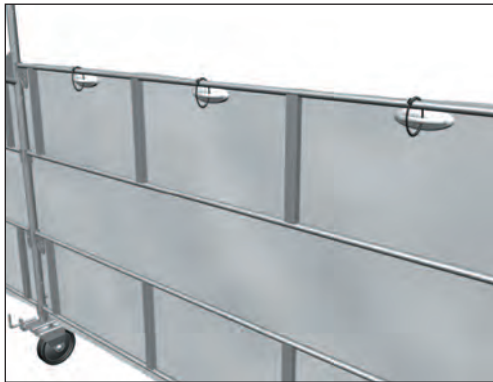
WIDTH: 3.05m  
HEIGHT: 2.5m

## SIDE SHEETS (3.05m x 2m)

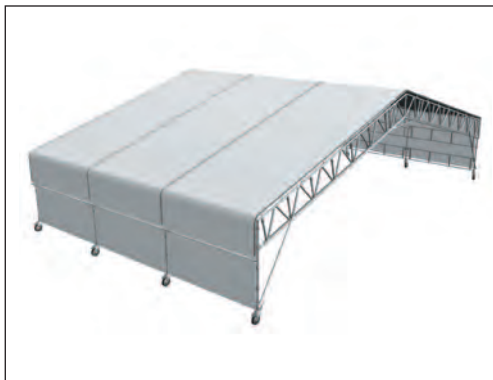


**Figure 33**

These are attached to the side framework of the Shelter, via 'D' rings on the sheet using suitable Cable Ties or similar.



**Figure 33a**



**Figure 34**

Completed Shelter 3 bays

long.

### Name

**3.05m Tension Bar** 7500015  
8kg



**3.05m Sheeting Bar** 7500006  
6.8kg



**3.05m Tension Tube** 7500022  
9.2kg



**3.05m Pulling Device** 7500008  
8kg



## ADDITIONAL COMPONENTS REQUIRED FOR TOWER ERECTION

**Standards - 1m FSH** 7017101  
6kg



**Standards - 1m FS.SH open ended**  
UK7017105



**Standards - 2m FSH** 7017201  
11.3kg

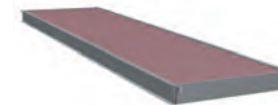
**Ledger Beam - 2.5m** 7021251  
15kg



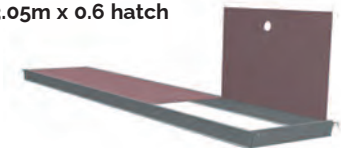
**Ledger Beam - 3.05m** 7021301  
18.8kg



**Hakidek - 3.05m x 0.6**  
UK2091301  
24.5kg



**Hakidek - 3.05m x 0.6 hatch**  
UK2091311  
25.5kg



**2.1 Aluminium Ladder** 2091210  
3.4kg

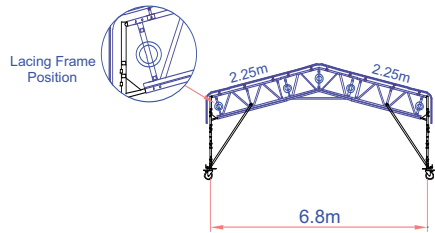


**Double Beam Rider**  
UK7208030  
6kg

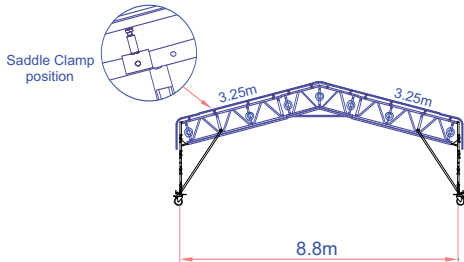


**Puncheon Jack Unit**  
UK7012110  
15kg

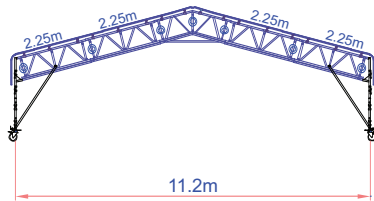




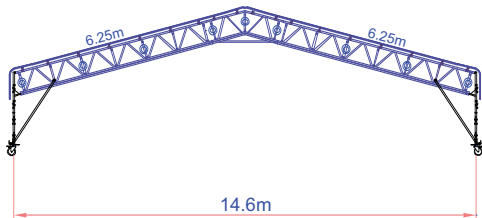
**6.8m Shelter**  
Sheet B = 10.88m



**8.8m Shelter**  
Sheet B = 10.88m

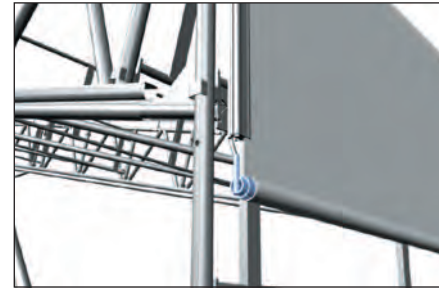


**11.2m Shelter**  
Sheet A = 16.88m



**14.6m Shelter**  
Sheet A = 16.88m

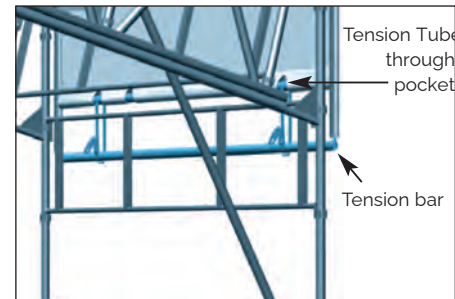
The scaffold tower required to erect the Shelter will have a plan dimension of 3.05m x 2.5m. The height of the tower will vary dependant on the shelter height.



**Figure 31a**

Insert the pegs on the Tension Bar into the clamp slot of the HAKI Trak whilst slowly pulling the sheet back to tension.

**Tensioning using end pocket**



**Figure 32**

At opposite end of sheet insert Tension Tube into its nearest pocket which is inside the HAKI Trak.

Fit Ratchet Straps around the Tension Tube and Tension Bar through the loops on these items (as shown on figure 32b).

Tighten Ratchet Straps until pegs on the Tension Bar are both located into the clamp slot and continue to tighten sheet.

**Tensioning using intermediate pocket**



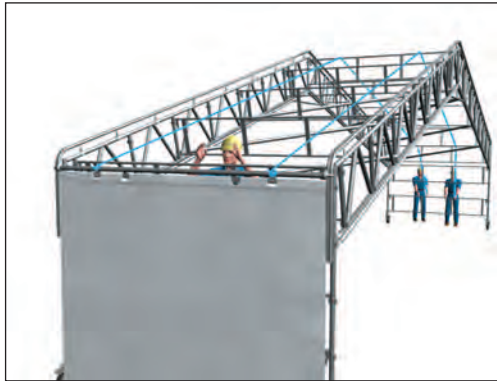
**Figure 32a**

**Note - Any spare sheet should be tucked up inside the Shelter.**



**Figure 32b**

Repeat procedure for all subsequent bays.



**Figure 29a**

Once the sheet is located in the track, operative 1 joins operative 3 to commence pulling the sheet.



**Figure 30**

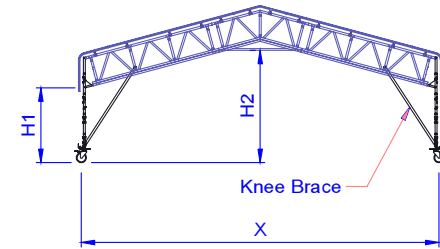
Operative 2 aids the installation of the sheet around the Corner. **Failure to do this will damage sheet.**

The sheet is pulled to the other side until the leading edge of the sheet is approximately 150mm beyond the track.



**Figure 31**

Remove pulling device and Sheeting Bar and replace with Tension Bar.



Side Arrangement	H1 Min & Max	Brace	H2 Min & Max			
			X = 6.8m	X = 8.8m	X = 11.2m	X = 14.6m
Shelter Bracket with No Standard	864 1164	-	1540 1840	1799 2099	2122 2422	2570 2870
Shelter Bracket with 0.5m Standard	1364 1664	1.25m	2040 2340	2799 2599	2622 2922	3070 3370
Shelter Bracket with 1m Standard	1864 2164	1.655m	2540 2840	2799 3099	3122 3422	4570 4870
Shelter Bracket with 1.5m Standard	2364 2664	2.5m	3040 3340	3299 3599	3622 3922	4070 4370
Shelter Bracket with 2m Standard	2864 3164	3.05m	3540 3840	3799 4099	4122 4422	4570 4870
Shelter Leg	1841 2141	1.655m	2517 2817	2776 3076	3099 3399	3547 3847

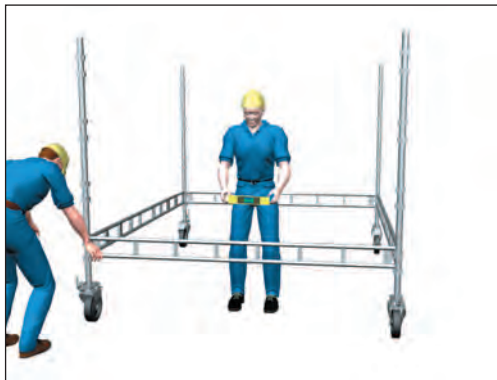
## INTRODUCTION

This user manual is based on erecting a shelter with a minimum 3 **competent** operatives from a fully guardrailed tower of plan dimensions 3.05m x 2.5m.

The platform height will vary dependent on the shelter width and height (see shelter sections on pages 6 and 7). All operatives must have the correct P.P.E.

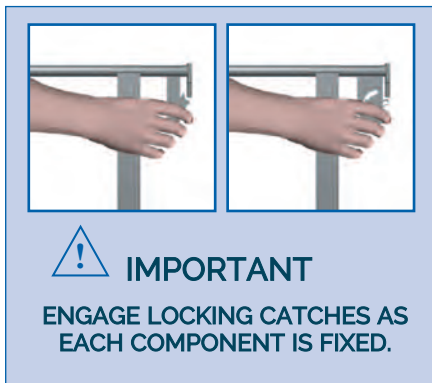
## TOWER ERECTION

Commence erection at highest ground level at the shelter position.



**Figure 1**

Insert wheels into standards, connect Ledger Beams or Frames in lowest pocket position to form a tower, and level.



**Figure 2**

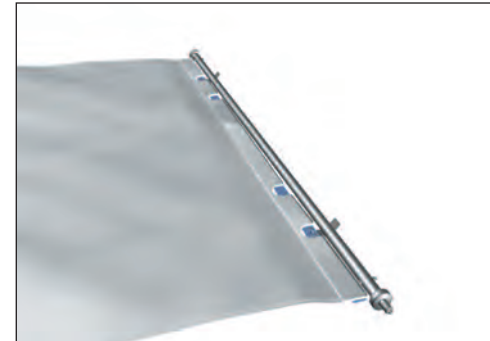
Add frames to form second level.



## ROOF SHEETING

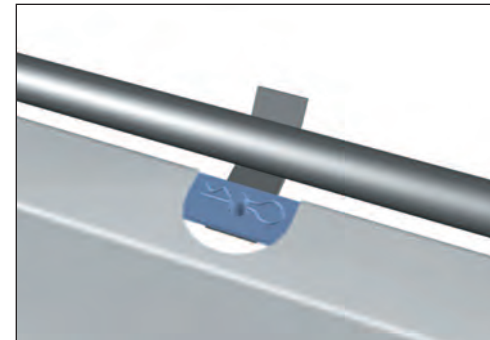
**Type A Sheet (16.88m long) is used on 14.6m wide and 11.2m wide Shelters.**  
**Type B Sheet (10.88m long) is used on 8.8m and 6.8m wide Shelters.**

Arrange the sheet such that the pockets on the sheet will be on the inside of the Shelter.



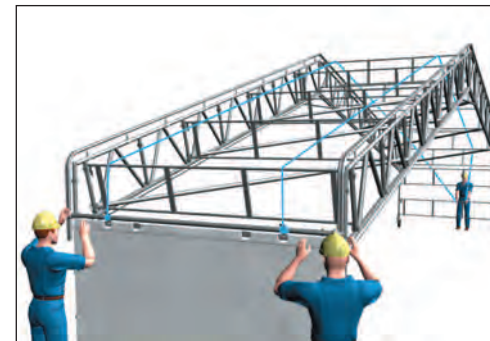
**Figure 28**

Slide the Sheeting Bar into the end pocket.



**Figure 28a**

Attach the pulling device to the Sheeting Bar with the retaining Clip.

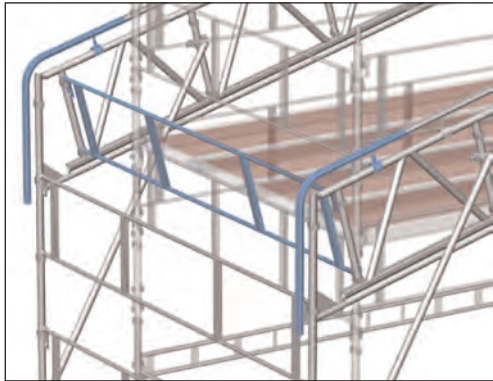


**Figure 29**

Attach the ropes onto the pulling device.

Operatives 1 and 2 raise the sheet and locate the cords of the sheet into the HAKI Trak, whilst operative 3 takes up the slack with both ropes.



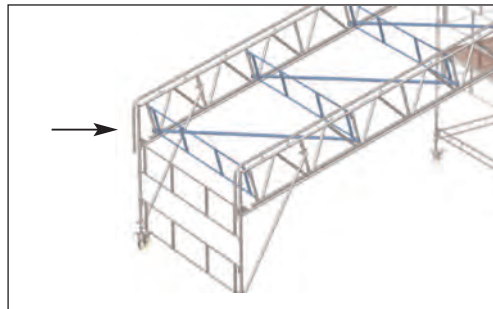


**Figure 25**

Move tower to the end of Shelter.  
Locate 1st Lacing Frame. Secure end Track.



**Figure 25a**



**Figure 26**

Move Tower towards Ridge to enable all additional Lacing frames to be fitted along with plan braces. Note - plan braces will not fit unless the bay is square. Move Shelter Leg until brace fits.

Plan Bracing frequency every end bay and every 5th bay in between; at ridge use tube and fittings.

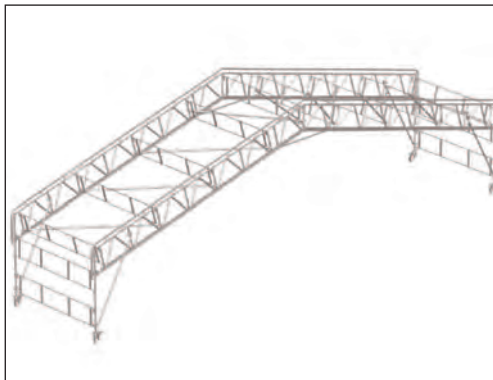
Repeat for opposite side of bay.

**Plan Bracing is essential for rigidity of the structure.**

**Figure 27**

Completed Bay of framework.

For additional bays repeat procedure from figures 6-26.



**Note - Prior to commencing sheeting, the Shelter must be prevented from lifting with anchors or kentledge. (See guidance note on page 22)**



**Figure 3**

Temporarily place Hakideks to enable Top Standards and Guard Frames to be fitted.



**Figure 4**

Fully deck out working level and position ladder.



**Figure 5**

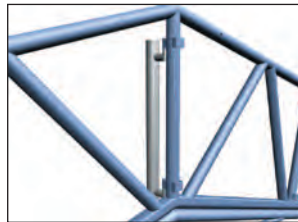
Locate double beam rider onto middle of 2.5m guard frame and insert Puncheon Jack Unit at platform level.

## SHELTER ERECTION



**Figure 6**

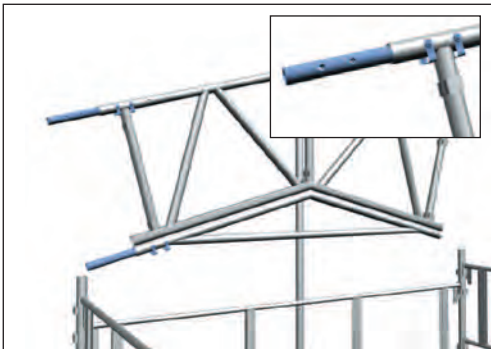
Hang Ridge Frame on the Puncheon Jack Unit tongues and lock catch.



**Figure 7**

Insert Connector Tubes in top and bottom chords of the Ridge Frame, secure using Spring Pins (2 per connector tube).

**Note - For convenience the Ridge Frame will rotate thus facilitating easy and safe fixing of all Connector Tubes.**



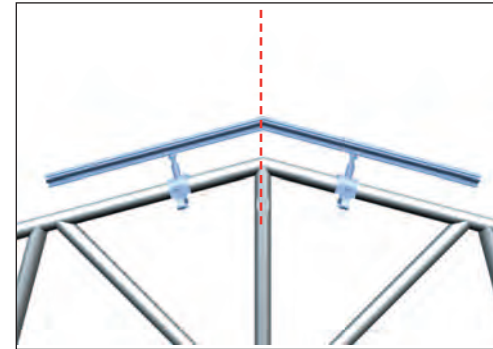
**Figure 8**

Insert Shelter Leg into end of beam and secure with 4 Spring Pins. Locate Wheels/base jack into bottom of Shelter Leg.



**Figure 8a**

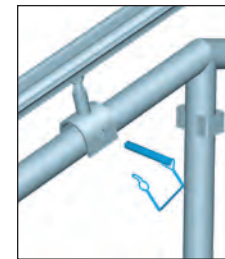
Insert Access Shelter Bracket into end of Beam and secure with four Spring Pins. Fit required size Standard into Access Shelter Bracket, secure with Pin & Chain and locate Wheels/Base Jack into bottom of leg.



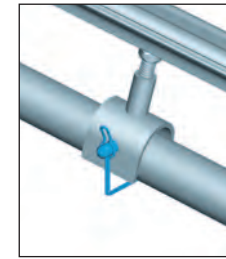
**Figure 22**

Fix Hakitrak Ridge via holes in top chord of Beam and secure with two Spring Pins ensuring that the spring is fully engaged. **Tighten nut with 22mm open ended spanner.**

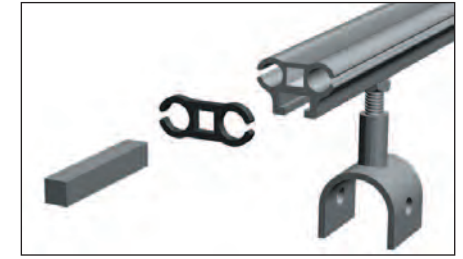
**Note - Ensure Track is central to Ridge Frame.**



**Figure 22a**

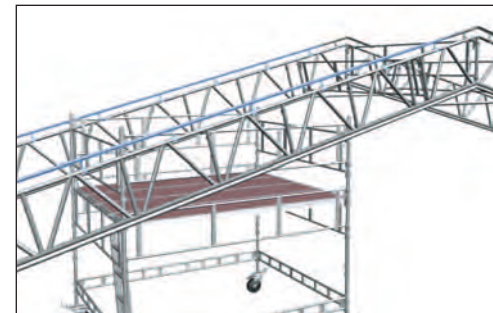


**Figure 22b**



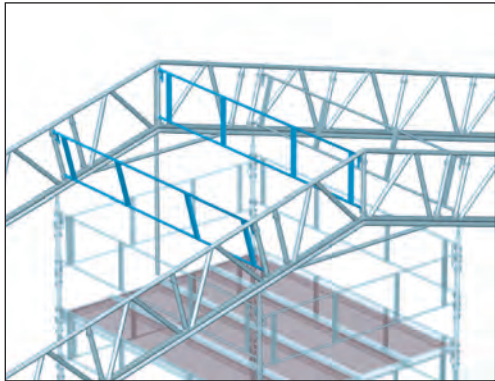
**Figure 23**

Prepare next HAKI Trak section by adding joiner and seal.

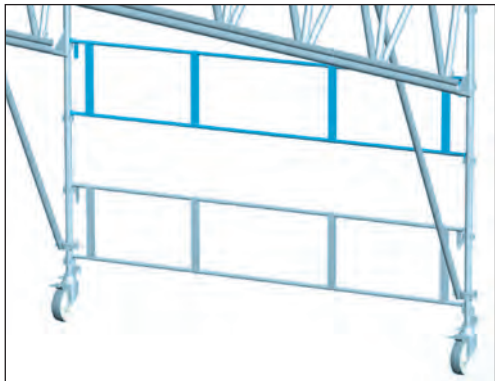


**Figure 24**

Rotate tower through 90° and move to enable the next HAKI Trak section to be fitted.



**Figure 19**  
Fit additional 2 Lacing Frames to Ridge Frame.



**Figure 20**  
Add Frames between Shelter Legs.

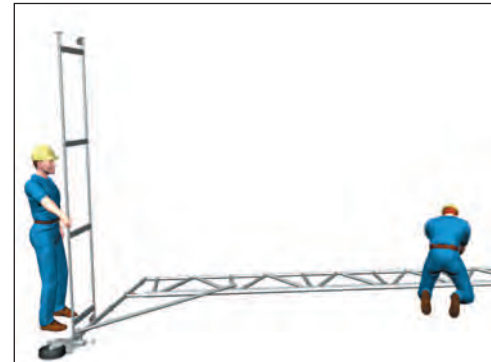
Release Puncheon Jack Unit for use on subsequent Truss erection (as shown on figure 16).



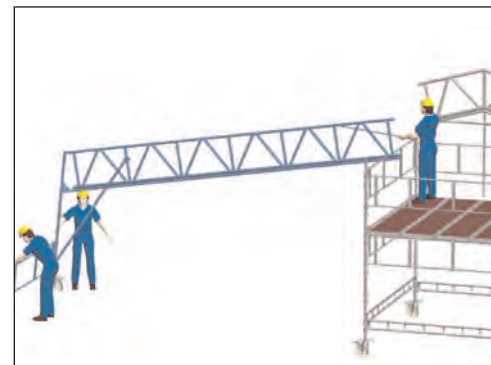
**Figure 21**  
Slide saddle clamps into HAKI Trak sections (for quantity see component list).



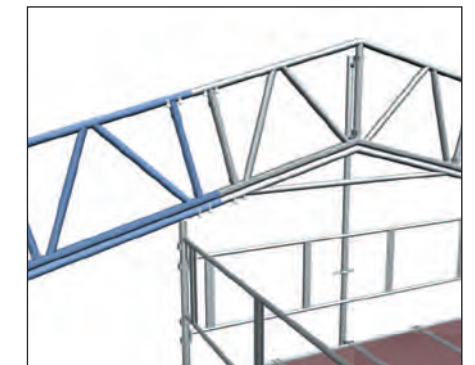
**Figure 9**  
Locate the required Diagonal Brace (see page 7) onto Shelter Leg/Standard and on the vertical strut of the Aluminium Beam.



**Figure 10**  
Fit frame into bottom set of pockets of Shelter Leg, attach rope to beam and pass the rope to the operative on the tower.



**Figure 11**  
Raise the beam, Shelter Leg and frame to enable the beam to be connected to the ridge frame.

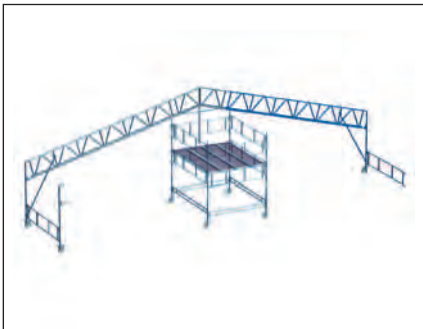


**Figure 12**  
Manoeuvre and slide assembly into position and secure with 4 Spring Pins.

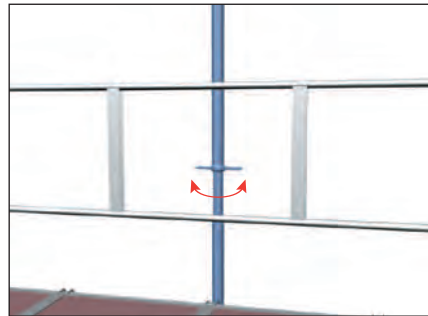


**Figure 13**  
Fit Shelter Leg or Standard temporarily to stabilize the structure whilst construction of the 2nd half of truss is completed.

Repeat the procedure from figure 8 to figure 12 to complete the assembly of the other side of the Truss.



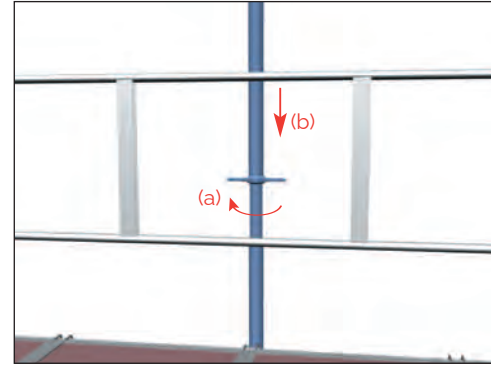
**Figure 13a**



**Figure 14**  
Adjust the Puncheon Jack Unit to level the Ridge Frame.

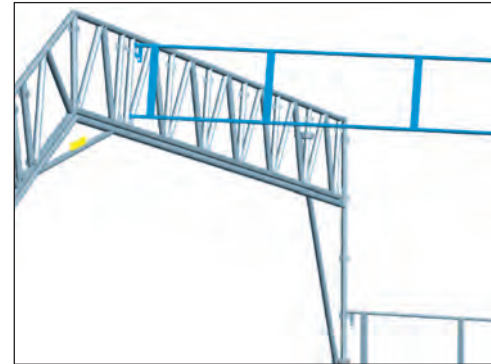


**Figure 15**  
Adjust Wheel/base Jack if ground level requires.



**Figure 16**  
Release Puncheon Jack Unit to enable it to be removed and reposition on opposite side of Tower.

To build 1st half of 2nd Truss repeat procedures from figures 6-12 (but commencing from the opposite side from the temporary Shelter Leg.)



**Figure 17**  
Working from the safety of the tower, locate Lacing frame into pockets on Ridge Frame, and level.

N.B for Lacing Frame positions see page 6.



**Figure 18**  
For 2nd half of this Truss repeat (8-12) but note to enable the permanent Shelter Leg to be fitted the temporary one must be removed.